

**variset VZ range**  
 single width island with hangers  
 and shelf. can also be used against  
 hollow or partitioned walls

# VZ13

PLAN

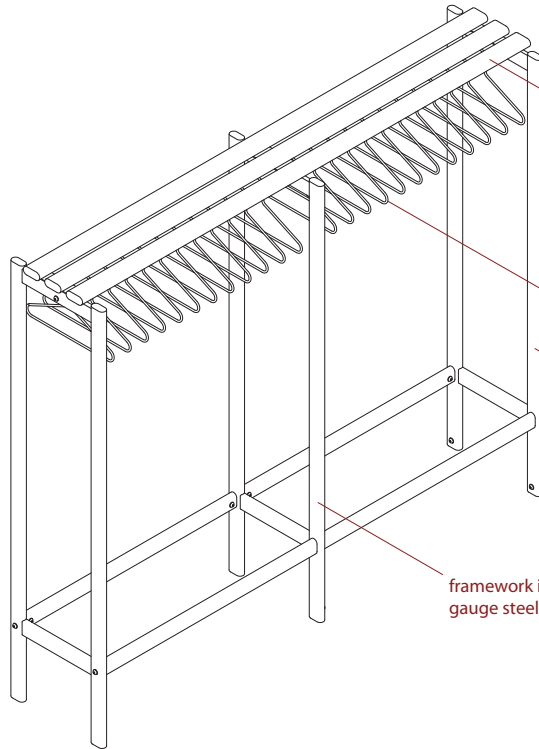
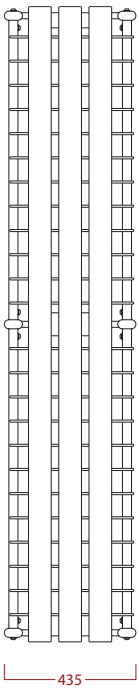

shelves are produced from sustainable european white beech slats 32 x 75mm and finished with a clear acid-catalysed lacquer. timber slats are trimmed on site to the exact length to fit the desired space. aluminium shelving slats are available for the toughest of environments or where a high level of humidity is present.

6mm plastic coated steel rod hangers

the finish of the range is powder coated in colour combinations from the full RAL range

framework is made from hollow section heavy gauge steel tube and is a fully welded assembly



END ELEVATION

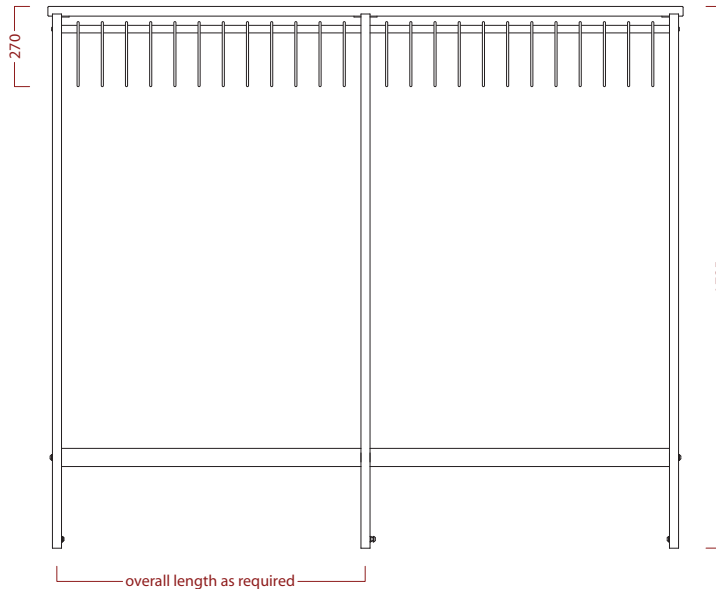

FRONT ELEVATION



**N10 GENERAL FIXTURES/FURNISHINGS/EQUIPMENT**

**VZ13 210 COAT RACKS For Changing Rooms**

**MANUFACTURER** AJ Binns Limited, Harvest House, Cranborne Road, Potters Bar, Hertfordshire, EN6 3JF. Telephone 01707 855 555 fax 01707 857 56

email enq@ajbinns.com web www.ajbinns.com

PRODUCT REFERENCE Description

**MATERIAL** Material/Material/Material

**FINISH/COLOUR** Finish/Colour

**FITTINGS** Fittings/Fittings/Fittings

# binns

variset **benches, hooks, hangers & shelves** for changing rooms & cloakrooms  
 variset® is designed by Royal Designer for Industry Kenneth Grange CBE, RDI

**AJ Binns Limited**

Harvest House, Cranborne Road  
 Potters Bar, Hertfordshire EN6 3JF  
 Telephone 01707 85 5555 Fax 01707 85 7565  
 email enq@ajbinns.com  
 web www.ajbinns.com